



BASIC SPECIFICATIONS

Dual Voltage: Either 115 or 230 volts ac. -- 50/60 hertz

Contacts: Silver Cadmium oxide.

Contact Ratings: 10 amperes at 120 or 240 volts ac. - or 28 volts dc.; 1/4 hp at 120 volts ac. and 1/3 hp at 240 volts ac.

Arrangement: Double pole, double throw load contacts plus single pole, double throw holding circuit contacts.

Power Required: 9 volt-ampere, 6 watt.

Low Energy Sensing Circuit: A.C. - 8 volts (less than 30 milliamperes) for 5200-L. D.C. - 9.6 volts (less than 1 milliampere) for 5200-H.

PRINCIPLE OF OPERATION

B/W Series 5200 Solid State Controls are offered in two basic types for use in a wide range of low and high sensitivity applications. Both are designed to operate on either 115 or 230 volts ac at 50/60 hertz. Both incorporate a low voltage sensing circuit. Both are also capable of performing control functions directly from electrodes suspended in a well or tank, the B/W Unifloat level sensing system, or various pilot devices such as pressure, flow and limit switches, thermostats and pushbuttons, etc.

In addition, their operating characteristics are virtually unaffected by ambient temperatures ranging from -40°F to +180°F, or by variations from 80% to 110% of their rated voltage. Both controls are also furnished with a complete set of R1 fixed sensitivity resistors or a variable resistance potentiometer to permit adjustment of operation based on the resistance of the liquid or material to be controlled. See tables below.

Series 5200-LF1 Low Sensitivity Control

The basic components of this control are transformer, a circuit board with voltage divider circuit, a silicon controlled rectifier (SCR), and a load to provide isolated DPDT contacts. The sensing circuit voltage is 8.0 volts ac.

Series 5200-HF2 High Sensitivity Control

This control is similar to the Series 5200-LF1, but with two basic differences: First, a rectifier is used to convert the sensing circuit voltage from ac to 9.6 volts dc; second, a field effect transistor (FET) is added to provide higher sensitivity. This permits positive operation on liquids with very high resistance.

Since the voltage divider circuit compares the liquid resistance to the R1 sensitivity resistor on both Series 5200-LF1 and Series 5200-HF2 controls it is important that the R1 resistor selected be rated higher than the resistance of the liquid or other sensing circuit.

Series 5200-LF1 Low Sensitivity Control

R1 Sensitivity Resistor	Maximum Lead Wire Lengths*	Application Recommendations
270 ohms	15,000 feet	All metallic circuits, B/W Controls Unifloat
470 ohms	15,000 feet	Strong electrolytes: Plating solutions.
1,000 ohms	15,000 feet	Weak electrolytes: Ammonium hydroxide, borax, acetic acid
1,800 ohms	11,000 feet	Most food processing applications: Beer wine, fruit juices, milk buttermilk
3,900 ohms	5,000 feet	Highly corrosive acid or caustic solutions where electrode current must be minimized to extend electrode life: Hydrochloric acid, sulfuric acid, etc
10,000 ohms	2,000 feet	Ordinary water with medium to high mineral content, sewage, water soluble oil and starch solutions.
22,000 ohms	900 feet	Sugar syrup solutions, most water with low mineral content. (Soft water-not distilled or deionized water. Use Series 5200-HF2 Control)

*Distance shown in the tables above are based upon the use of two 18-gauge lead wires installed in 1/2" diameter conduit.

Direct Operation

In direct operation, the load relay is *energized* when the level sensing circuit is completed.

When operating from electrodes for pump down operation, and liquid is below lower electrode, a high resistance is sensed across terminals 13 & 14, and a negative, or out-of-phase, signal is fed to the SCR. When liquid rises to touch the upper electrode, a low resistance is sensed across terminals 13 & 14, and the signal to the SCR becomes positive, or in-phase, turning the SCR on, which, in turn, energizes the load relay to start the pump. When load relay is energized, the holding circuit contact (4-7) closes to hold in the relay through the lower electrode and the liquid resistance until liquid level falls below the lower, or pump stop, electrode, at which time the SCR turns off and de-energizes the load relay to stop the pump.

Inverse Operation

In inverse operation, load relay is *de-energized* when the level sensing circuit is completed. In this mode of operation, function of load relay is reversed. When operating from electrodes for pump up operation, and liquid is below lower electrode, a positive, or in-phase, signal turns the SCR on, energizing the load relay to start the pump. When liquid rises to touch the upper electrode, a negative, or out-of-phase, signal turns the SCR off, de-energizing load relay and stopping the pump. The holding circuit contact (1-7) closes, keeping the load relay de-energized until liquid again falls below lower electrode.

Series 5200-HF2 High Sensitivity Control

R1 Sensitivity Resistor	Maximum Lead Wire Lengths*	Application Recommendations
1,000 ohms	50,000 feet	Ordinary water with medium to high mineral content, sewage, water soluble oil and starch solutions, long distance applications
22,000 ohms	50,000 feet	Water with low mineral content (soft - not distilled or demineralized), sugar syrup solutions, long distance applications.
68,000 ohms	50,000 feet	Steam condensate, corn syrup, strong alcohol solutions up to 50%
330,000 ohms	50,000 feet	Alcohol solutions up to 70%
820,000 ohms	35,000 feet	Deionized or distilled water, 95% glycerine, 90% hydrogen peroxide, 95% ethyl alcohol, granular solids with high moisture content
2.2 megohms	12,000 feet	Glacial acetic acid, acetone, granular solids with some moisture content
5.6 megohms	4,000 feet	M.E.K. (Methyl ethyl ketone)
12.0 megohms	2,000 feet	Anhydrous ammonia

NOTE: DI water, glycols, alcohols and granular solids may require the 2.2, 5.6 or 12.0 megohms R1 resistor depending upon their purity or moisture content.

INSTALLATION INSTRUCTIONS

These instructions relate primarily to the B/W electrode system of liquid level sensing. See B/W Form Z66 for complete specifications, wiring and electrode equipment, etc.

ELECTRODE LEAD WIRES

Shielded cable is not required. Generally the size of the wire used is passed upon the physical strength required to meet given installation condition. Size 14 to 18 gauge wire is generally strong enough for private buried or overhead wiring, although size 26 gauge wire is adequate for positive relay operation. In some long distance applications, communication cable or telephone circuits may be used. In all cases, however, control circuit wires must have good insulation, and splices or connections must be watertight and insulated from ground.

Special Note -- In order to prevent feed-back which can cause faulty operation, electrode lead wires should not be run in the same conduit with power or load carrying circuits.

ELECTRODE LEAD WIRE LENGTH

Series 5200-LF1 Low Sensitivity Control

These controls operate with 8 volts ac on the sensing circuit, and in general, the maximum lead length is determined by the capacitance of the lead wires and the value of the R1 sensitivity resistor. Refer to Table on page 1 for suggested maximum lead lengths.

Series 5200-HF2 High Sensitivity Controls

These controls operate with 9.6 volts dc on the sensing circuit, and in general, the maximum lead length is determined by the resistance of the lead wires. These controls will operate reliably with electrode lead lengths of several miles, but it is important to select the correct R1 sensitivity resistor to assure positive operation over these extreme distances. Refer to Table on page 1 for suggested maximum lead lengths. If your application involves greater distances than those shown, please contact factory.

GROUND CONNECTIONS

In all installations using electrodes, a good external ground connection and a dependable return circuit to the liquid are required. In most instances, grounding to a metal pipe leading to the tank is suitable, but electrical conduit should not be used for this purpose.

If a good ground connection to the liquid is not available, an additional ground or common electrode is required. When used, the ground or common electrode should extend slightly below the longest operating electrode. In addition, it is also desirable to ground the control chassis directly to the ground terminal or through a mounting screw.

If PVC well casings or drop pipes are used to contain the electrodes, a ground or common electrode is required.

R1 SENSITIVITY RESISTORS

Both the high sensitivity and the low sensitivity controls are shipped from the factory with a complete set of fixed resistors or with a variable resistance potentiometer. Variable resistance potentiometers are furnished in three different ranges according to the table which follows.

Sensitivity Ranges

Relay Type	R1 Resistor	Direct Operation	Inverse Operation
5200-LF1	Fixed R1 Resistor	Up to 16,000 ohms	Up to 26,000 ohms
5200-LV1	Variable	100 to 700 ohms	200 to 1,200 ohms
5200-LV2	Variable	600 to 15,000 ohms	1,000 to 24,000 ohms
5200-HF2	Fixed R1 Resistor	Up to 11.6 megohms	Up to 12.0 megohms
5200-HV3	Variable	2,000 to 100,000 ohms	2,000 to 100,000 ohms
5200-HV4	Variable	.007 to 1.0 megohms	.007 to 1.0 megohms
5200-HV5	Variable	.047 to 5.0 megohms	.047 to 5.0 megohms

To determine which fixed sensitivity resistor to install, please refer to the table which follows. When operating from electrodes, select a resistor having a sensitivity value greater than the specific resistance of the material to be controlled. Any of the resistors can be used when operating from switch contacts, but the smallest value is recommended. Fixed resistance R1 resistors should be installed as shown on the wiring diagram furnished with the control.

Fixed Resistor Sensitivity

Series 5200-LF1 Sensitivity Control		Series 5200-HF2 High Sensitivity Control	
Part Number	Nominal Resistance	Part Number	Nominal Resistance
04-154900	270 ohms	04-149400	10,000 ohms
04-155000	470 ohms	04-138400	22,000 ohms
04-138300	1,000 ohms	04-138500	68,000 ohms
04-155100	1,800 ohms	04-138600	330,000 ohms
04-155200	3,900 ohms	04-138800	820,000 ohms
04-149400	10,000 ohms	04-138900	2.2 megohms
04-138400	22,000 ohms	04-139000	5.6 megohms
		04-139100	12.0 megohms

SERVICE INSTRUCTIONS

B/W Solid state controls are designed and built to require a minimum of service in the field. Each one is tested at the factory to insure positive operation, and should not be altered or tampered with prior to installation. If a control does not operate properly after it has been installed with the proper sensitivity resistor added, the following information will be helpful in determining the probable cause.

DIRECT OPERATION

In direct operation, the load relay is energized when the liquid reaches the upper electrode or Unifloat reed switch level, and electrode current is flowing. Be sure sensitivity resistor has been installed between terminals 14 and 15, and a good ground connected to terminal 13.

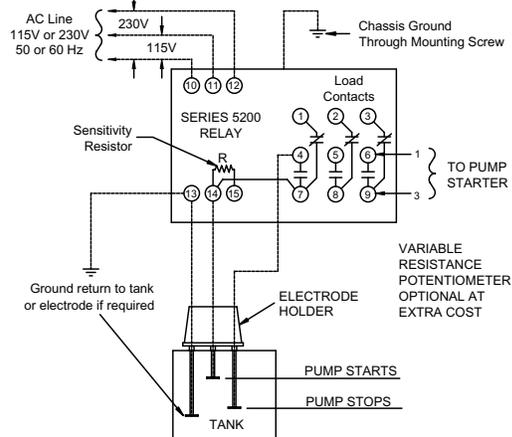

PUMP DOWN

A - Load Relay Will Not Pull In

1. Power Failure or No Voltage at AC Line Terminals

Voltage at power in-put terminals should be 115 volts ac between terminals 10 & 11 or 230 volts ac between terminals 10 & 12.

2. Defective Control

To check control, disconnect electrode and load connections from control terminals. Apply line voltage to the appropriate terminals (10-11) or (10-12), and touch terminals 13 and 14 with an insulated jumper wire. Load relay should pull in when the jumper is connected, and drop out when the jumper is removed. Failure to do so indicates a defective control.

3. Poor Ground Connection

Controls will not function unless a good dependable ground connection is made to terminal 13. If a load relay does not pull in when liquid contacts the upper electrode, check ground connection to be sure it complies with installation instructions.

4. Broken Wires

A broken or loose wire from the control to the upper electrode or the ground (common electrode) will prevent load relay from pulling in. Broken wires can be checked by shorting the upper electrode to ground, or to the common electrode if used, at the electrode holder. If relay fails to pull in, one or both of the electrode leads is open. The individual leads can be checked by running temporary wires from the control to the electrode holder outside of conduit. If the load relay now pulls in, when shorting electrodes as noted above, the break is between the control and electrode holder. If load relay pulls in when the leads are shorted with a jumper at holder, but not at electrode tips, the break is in the electrode suspension wire.

5. Sensitivity Resistor Too Low

If the sensitivity resistor value is too low for the resistance or conductivity of the liquid to be controlled, the load relay will not pull in, or it will buzz and chatter before pulling in. In either case, the sensitivity resistor should be replaced with a higher value resistor (see table, page 2). If in doubt about R1 resistor selection, furnish factory with details on liquid, or send sample of liquid for testing.

6. Fouled Electrodes

Accumulation of dirt, oil, grease, or other deposits on the electrodes may insulate them and prevent load relay from pulling in. If this occurs, the electrodes should be inspected and cleaned at regular intervals, as required, to eliminate the difficulty. If unusual quantities of oil, grease or sludge are encountered, the electrodes can be mounted inside a pipe that is flushed with clean water. A 4" pipe should be used -- with the bottom located below the lowest expected water level, and vent holes provided at the top so that the level inside and outside the pipe will be the same. A small flow of water entering the top of the pipe will cause an outward flow of water from the bottom of the pipe and prevent undesirable material from entering. Thus, the electrodes have a clear surface on which to operate, and will stay clean.

7. Electrodes Too Short

It is possible for an installation to be completed in which the upper electrode is suspended at a point where the liquid cannot make contact. All installations should, of course, be checked to make sure that the proper electrode lengths are provided. If stand pipes are used, make sure pipe is vented above upper electrode setting.

B - One Level Operation

If control operates at one level only (starts and stops at one electrode level) check following:

1. Electrode Wires

If wires between control and electrodes are interchanged, load relay will not operate over a range in level, but from the lower electrode only. To correct, simply reverse electrode connections either at terminal strip or electrode holder.

2. Holding Circuit

If the holding circuit (terminals 4--7) is not closing, the load relay will operate from the upper electrode only. If the holding circuit is not opening, the relay will operate from the lower electrode only. This holding circuit contact can be checked for continuity with an ohmmeter. If defective, and if contacts 2-5-8 are not being used for load connections, contacts 5-8 can be used as a holding circuit contact. Move the internal jumper from terminal 7 to terminal 8, and move the lower electrode connection from terminal 4 to terminal 5.

C - Intermittent Operation

If the control occasionally short cycles or operates intermittently, check the following:

1. Continuously monitor input voltage for fluctuations or voltage spikes.
2. Check for physical vibration caused by contactors or magnetic starters mounted nearby.
3. Check A-4 & A-6.

D - Constant Chatter

If load relay contacts chatter continuously, check defective control as in A-2.

1. If relay now operates correctly, check A-4 & A-6; B; C-1 and C-2.
2. If relay still chatters with terminals 13 & 14 jumpered together, the load relay is defective, or the capacitor across the load relay coil may be defective.

E - Load Relay Will Not Drop Out

If relay will not drop out when liquid falls below lower electrode, check the following points:

1. Defective Control -- See A-2.
2. Grounded Electrode Leads

A ground in the lead wire to the upper or lower electrode will prevent the relay from dropping out on low liquid level.

If the distance from the holder to the control is relatively short, the best way to check for ground is to connect replacement wires from the terminal strip to electrode holder, outside of conduit, and test for proper operation. If load relay drops out properly, it is safe to assume that a ground exists in the original wires to the electrode holder.

If control is located a considerable distance from the electrode holder, check for ground as follows: Disconnect power, remove wires from terminals in electrode holder, and allow them to stick up in the air to eliminate the possibility of contacting a grounded part. Then turn on power. If load relay pulls in, a short is indicated in the upper lead wire to ground between the control and the electrode holder.

If the load relay does not pull in, short the relay with a piece of insulated wire by bridging between relay terminals 13 & 14. The load relay should pull in when this connection is broken. If the relay does not drop out, a short to ground is indicated in the lower electrode lead between the control and electrode holder. If any of these conditions exist, disconnect the power and replace the grounded wires.

3. Electrode Holder

Excessive dirt or moisture over the insulation at the electrode holder or the electrodes can cause faulty operation. The interior of the electrode holder and its underside should be kept clean and dry. Conduit connection should be made so that no condensation can enter the holder. The underside of vertically mounted holders should never come in contact with the liquid. Insulated rod electrodes should be used with horizontally mounted holders. Electrodes should be kept clean and free of dirt or grease. A periodic check should be made to make sure that they do not become fouled with floating debris or insulating deposits.

4. Length of Electrode Lead Wire

On installations with excessive distance (over 1,000 feet) between a Series 5200-LF1 low sensitivity control and the tank, capacitance in the lead wires from the control to the electrodes may affect normal operation. If wired for direct operation, capacitance would cause the load relay to hold in when the liquid leaves the lower electrode. If wired for inverse operation, the load relay would fail to pull in. In this event, a Series 5200-HF2 high sensitivity control should be used.

INVERSE OPERATION

In inverse operation, the relay is energized when liquid falls below the lower electrode, and current ceases to flow. Be sure sensitivity resistor has been installed between terminals 13 & 14, and a ground connected to terminal 15.

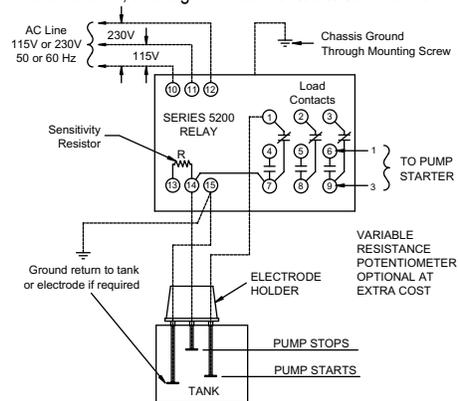

PUMP UP

F - Load Relay Will Not Pull In

If relay will not pull in when liquid drops below lower electrode, failure to operate is probably caused by one of the following conditions:

1. Power Failure or No Voltage

See Section A-1 under Direct Operation.

2. Defective Controls

To check the relay, disconnect electrode and load connections from relay terminals. Apply line voltage to the appropriate terminals, (10 & 11 or 10 & 12), and short between terminals 14 & 15 with an insulated jumper wire. The load relay should drop out when the jumper is connected and pull in when the jumper is removed. Failure to do so indicates a defective control.

3. Grounded Electrode Leads

A ground in the lead wire to the upper or lower electrode will prevent the load relay from pulling in. Section E-2 describes how to isolate the grounded wire when the relay is being used for direct operation. This same method can be used when the control is being used for inverse operation, but the functions must be reversed. (i.e. "drop out" interchanged with "pull in"). In section E-2, bridge between terminals 14 & 15 instead of 13 & 14.

4. Electrode Holder -- See Section E-3

5. Length of Lead Wires

Excessive distance will not allow the Series 5200-LF1 low sensitivity control to operate when the liquid drops below the lower electrode. See Section E-4.

G - One Level Operation

If load relay operates at one level only (starts and stops at one electrode), check following:

1. *Electrode Wires* -- See Section B-1.

2. Holding Circuit

If the holding circuit (contacts 1-7) is not opening, the load relay will operate from the lower electrode only. If holding circuit is not closing, the relay will operate from the upper electrode only. As in Section B-2 for direct operation, if contact 1-7 is defective, contacts 2-8 can be used as an alternate holding circuit contact.

H - Intermittent Operation

If load relay occasionally short cycles or operates intermittently, check the following:

1. See Section C-1 and C-2.
2. Check Section J-3 and J-5.

I - Constant Chatter

If load relay chatters continuously, check as in Section F-2. If relay now operates correctly, check Sections J-3 & J-5, G, and H.

If load relay still chatters with terminals 14 & 15 disconnected, the relay is defective or there is a defective capacitor in the circuit board.

J - Load Relay Will Not Drop Out

If the relay will not drop out when the liquid touches upper electrode, check the following:

1. *Defective Control* -- See F-2.

2. Poor Ground Connections

A good dependable ground connection should be made to terminal 15 to complete the circuit back to terminal 14 as indicated in Section A-3.

3. Broken Wires

A broken or loose wire from the control to upper electrode or ground (common electrode) will prevent load relay from dropping out. Check as in Section A-4, but "pull in" should be replaced with "drop out" in the description.

4. Sensitivity Resistor Too Low

If the sensitivity is too low, the load relay will not drop out, or will buzz and chatter. See A-5, but "pull in" should be replaced by "drop out".

5. Fouled Electrodes

Accumulated deposits on the electrodes will insulate them, and prevent the load relay from dropping out. See Section A-6.

6. *Electrodes Too Short* -- See Section A-7.

CONTROL REPAIRS

All B/W controls are tested at the factory prior to shipment to insure proper operation. They should be handled with care during installation to avoid breaking electrical connections. If the control does not operate properly after it has been installed, and service instructions indicate a defect, repair should be attempted only by an experienced electronic technician as follows:

CHECK TRANSFORMER

With the ac line voltage applied to terminals 10 & 11 or 10 & 12 as shown on Form 448, the following voltages should be read between the transformer wire connections on back of the control (±15%):

- Black to Orange 115 volts
- Black to Blue 230 volts
- Red to White 3.6 volts
- Red to Brown 7.2 volts
- Brown to White 3.6 volts
- Green to Yellow 30 volts

If these out-put voltages are not present, and in-put voltages check, the transformer is defective and should be replaced.

TEST CIRCUIT BOARD AND LOAD RELAY

Direct Operation:

Test the control as in A-2 with jumper between terminals 13 & 14. If load relay does not pull in, check on circuit board between two black wires leading from load relay for a reading of 22 to 26 volts dc. If the voltage reading is low, the circuit board is defective. If the voltage reading is high (39 to 44 volts dc), the load relay has an open coil.

Inverse Operation:

Test the control as in F-2 with jumper removed. If load relay does not pull in, check as above for 22 to 26 volts dc. If voltage is low, circuit board is defective. If voltage is high (39 to 44 volts dc), load relay has an open coil. Replace the circuit board or the load relay as required. See parts list for details.

If a competent technician is not available, the control should be returned to factory for repair or replacement.

Series 5200 Relay Chassis Dimensions

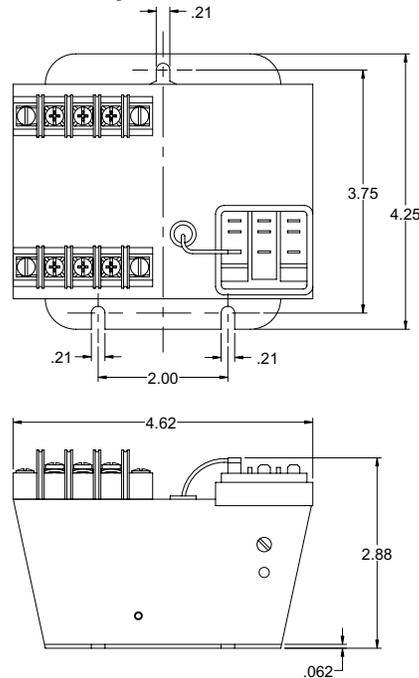

Replacement Parts

B/W Controls Series 5200 Solid State Controls

Description	Part Number
Resistor Set - Low	52-110105
Resistor Set - High	52-120105
*Potentiometer Kits for Series 5200-LV	
Range LV1	52-110205
Range LV2	52-110206
*Potentiometer Kits for Series 5200-HV	
Range HV3	52-120205
Range HV4	52-120206
Range HV5	52-120207
Circuit Board - Low	52-110114
Circuit Board - High	52-120114
Transformer	52-110106
Load Relay	04-261900
Terminal Block - Line	04-281900
Terminal Block - Probe	04-281800
*See Sensitivity Range table shown on page 2.	



1080 NORTH CROOKS ROAD • CLAWSON, MI 48017 USA
 800-635-0289 • 248-435-0700 • Fax 248-435-8120
 www.ametekapt.com • www.ametek.com

432
 5200 • M1R
 05/02 • Z152
 1M