

**Stik™ Continuous Level Sensor
 with Embedded DeviceNet™ Node**

Series 7260DN Stik Level Sensors combine the reliability and resolution of magnetostrictive continuous level sensing with the unique Stik Sensor packaging, and add the flexibility of DeviceNet communications, all in a single device. The magnetostrictive technology is the same as used in other Patriot level probes, proven in such demanding applications as leak detection in underground petrochemical tanks. The rugged, all welded stainless steel construction is ideal for harsh industrial environments. The all SMT electronic construction assures the ultimate in reliability.

The 7260DN plugs in as a node on any control system with a DeviceNet Scanner. Additional sensors are added by simply plugging onto the network. Continuous level data, with resolution of 0.01" is provided. In addition, eight (8) built-in user programmable set-points allow direct control of critical functions. All programming is done over the DeviceNet network.

The Series 7260DN provides flexibility and cost savings when compared to other methods of continuous level sensing. And when used to replace multiple discrete level sensors in the same tank, additional savings are realized. There is only one device to mount and wire, using mini-change plug connectors. Since every DeviceNet network is bus powered, there is no separate power supply to worry about. There are no port concentrators to buy, since all of the sensing and network electronics are embedded within the sensor's 5/8" diameter sensing tube. The 7260DN, with continuous level and eight (8) discrete set-points built-in, is competitive with only a few industrial grade set-point level sensors. Similar to the 960DN Linear Position Sensor, the 7260DN Level Sensor is hung in a tank or vat of liquid not requiring explosion proof or intrinsically safe controls, and uses a float with an embedded magnet target.*

Using the continuous level information from the 7260DN Stik Level Sensor, it is now feasible to have "intelligent" tanks and JIT wet stock inventory practices. This means that, in many cases, actual wet stock inventory investment can be measurably reduced, which translates directly to improved productivity and lower costs.

* For IS rated applications, use Series 7220 or 7100 products.



Reference Specifications
Resolution of 0.01"
Accuracy over Entire Span of +/- 0.1% of Stroke, or 0.050" min.
Response in Real Time on the DeviceNet Network
125K, 250K or 500K Baud Rates
Supports Bit Strobe or Pulling Modes
All Electronics Embedded in Sensor Tube
DeviceNet Node Embedded
Continuous Position Data, Plus 8 Discrete User Programmable Setpoints
Setpoints Programmable over the DeviceNet Network
-20°C to +70°C (-4°F to +158°F)
All 316 Stainless Steel Welded Construction in 5/8" Tube, Meets IP68
Mini-Change DeviceNet Connector
Available in 1" Length Increments of Stroke from 6" to 72" Standard, up to 192" Special Order
Any Standard Float* Suitable, Depending on Specific Gravity
* Floats Sold Separately Specifications may change without notice. Patent Pending

Series 7260 DN DeviceNet Level Sensor Part Numbers

7260 — DN — XXX — M — X — F1

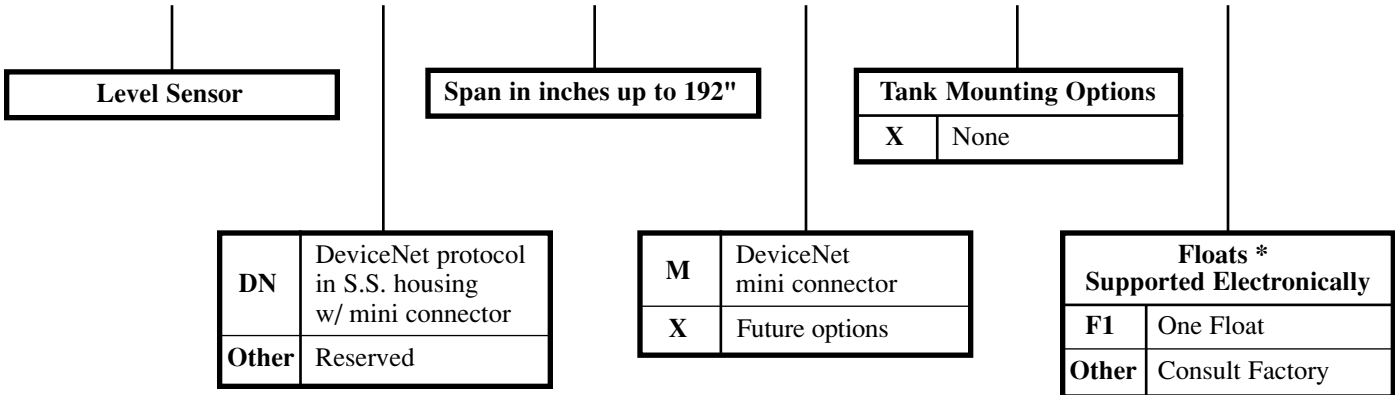

* Floats not included; order as separate item.

Engineering Data

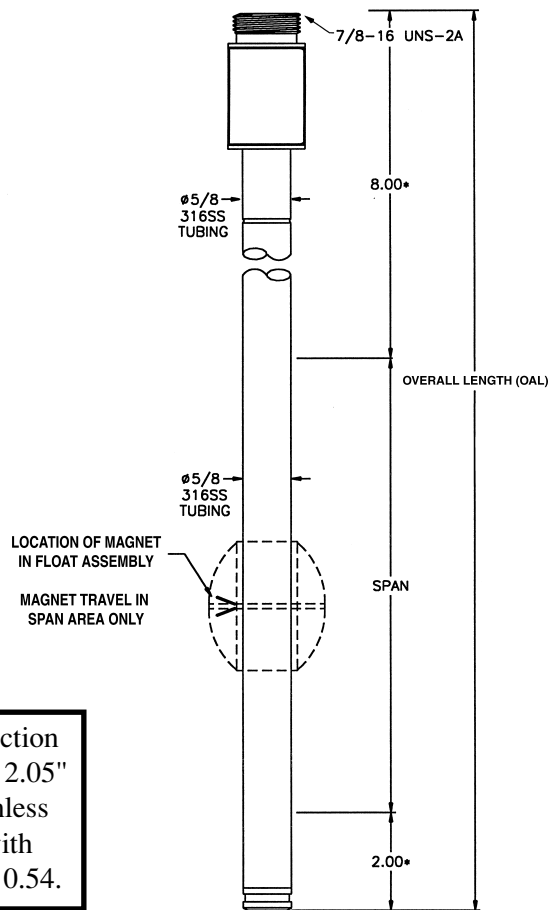

Standard float selection is P/N 14-020002, 2.05" diameter, 316 stainless steel "egg" float with specific gravity of 0.54.

AMETEK®
PATRIOT SENSORS

1080 NORTH CROOKS ROAD • CLAWSON, MI 48017 USA
800-635-0289 • 248-435-0700 • Fax 248-435-8120
www.patriotsensors.com • www.ametek.com

Form 1276
11/98•5000